

USER'S MANUAL

elevator door controller

type: **SDK-500**

firmware version: 1.22.0



Read the user's manual carefully before starting to use the unit.
TechWind company reserves the right to introduce changes without prior notice.

| | |
|-----------------------------------|--|
| Copyright | <p>Copyright © 2019, TechWind. All rights reserved.</p> <p>This document may not be copied or otherwise reproduced, in whole or in part, except as specifically permitted under international copyright law, without the prior written consent from TechWind.</p> |
| Disclaimer | <p>THE INFORMATION IN THIS DOCUMENT IS SUBJECT TO CHANGE WITHOUT NOTICE. TechWind ASSUMES NO RESPONSIBILITY FOR INACCURACIES OR OMISSIONS AND SPECIFICALLY DISCLAIMS ANY LIABILITIES, LOSSES, OR RISKS, PERSONAL OR OTHERWISE, INCURRED AS A CONSEQUENCE, DIRECTLY OR INDIRECTLY, OF THE USE OR APPLICATION OF ANY OF THE CONTENTS OF THIS DOCUMENT. FOR THE LATEST DOCUMENTATION, CONTACT YOUR LOCAL SUPPLIER OR TechWind COMPANY.</p> <p>This publication may contain examples of screen captures and reports used in daily operations. Examples may include fictitious names of individuals and companies. Any similarity to names and addresses of actual businesses or persons is entirely coincidental.</p> |
| Trademarks and patents | <p>TechWind name and logo are registered trademarks of TechWind company. SDK-500 product and logo are registered trademarks of TechWind company.</p> <p>Other trade names used in this document may be trademarks or registered trademarks of the manufacturers or vendors of the respective products.</p> |
| Software license agreement | <p>Software and firmware supplied with products is proprietary and furnished under license and can be used or copied only in accordance with the license terms.</p> <p>THE ENCLOSED PROGRAM IS FURNISHED SUBJECT TO THE TERMS AND CONDITIONS OF THIS AGREEMENT. RETENTION OF THE PROGRAM FOR MORE THAN 30 DAYS, OPENING OF THE SEALED WRAPPER, IF ANY, SURROUNDING THE PROGRAM, OR USE OF THE PROGRAM IN ANY MANNER WILL BE CONSIDERED ACCEPTANCE OF THE AGREEMENT TERMS. IF THESE TERMS ARE NOT ACCEPTABLE, RETURN THE UNUSED PROGRAM AND ANY ACCOMPANYING DOCUMENTATION TO TechWind FOR A FULL REFUND OF THE LICENSE FEE PAID.</p> |
| Intended use | <p>Use this product only for the purpose it was designed for; refer to the data sheet and user documentation. For the latest product information, contact your local supplier or visit us online at www.techwind.pl</p> |
| European directives | <div style="display: flex; align-items: center;">  <p>The European directive "Waste Electrical and Electronic Equipment" (WEEE) aims to minimise the impact of electrical and electronic equipment waste on the environment and human health. To conform with this directive, electrical equipment marked with this symbol must not be disposed of in European public disposal systems. European users of electrical equipment must now return end-of-life equipment for disposal. Further information can be found on the following website: www.recyclethis.info.</p> </div> |

CONTENTS

| | |
|---|-----------|
| 1. SAFETY NOTES | 4 |
| 2. INTRODUCTION | 5 |
| 3. CONTROLLER INSTALLATION | 6 |
| 3.1. INSTALLATION..... | 6 |
| 3.2. ELECTRICAL CONNECTIONS..... | 6 |
| 3.3. POWER SUPPLY..... | 8 |
| 3.4. MOTOR..... | 8 |
| 3.5. ENCODER..... | 9 |
| 3.6. CONTROL INPUTS..... | 9 |
| 3.7. RELAY OUTPUTS..... | 11 |
| 3.8. EXTERNAL OPTICAL BARRIER..... | 12 |
| 3.9. INSTALL SWITCH..... | 12 |
| 3.10. OPTIONAL TERMINAL POSITION CONTACT (DOOR OPEN)..... | 13 |
| 3.11. OPTIONAL RS-485 INTERFACE..... | 14 |
| 3.12. EMERGENCY BATTERY POWER SUPPLY BUTTON..... | 14 |
| 4. CONTROLLER PROGRAMMING | 15 |
| 4.1. PROGRAMMING MENU..... | 15 |
| 4.2. EDITING PARAMETERS..... | 16 |
| 4.2.1. Numeric parameters..... | 16 |
| 4.2.2. Switch parameters..... | 16 |
| 4.3. MENU STRUCTURE..... | 17 |
| 4.4. MENU DESCRIPTION..... | 18 |
| 1. Doors data..... | 18 |
| 2. Speeds..... | 18 |
| 3. Calibration..... | 19 |
| 4. Working modes..... | 23 |
| 5. Inputs..... | 23 |
| 6. Outputs..... | 24 |
| 7. Photocell..... | 24 |
| 8. Access setup..... | 25 |
| 9. Region..... | 25 |
| A. Default set..... | 25 |
| 5. MESSAGES | 26 |
| 5.1. NORMAL OPERATION..... | 26 |
| 5.2. WARNING MESSAGES..... | 28 |
| 6. FIRST POWER-ON | 29 |
| 7. RS-485 INTERFACE HANDLING | 30 |
| 7.1. LIST OF REGISTERS..... | 31 |
| 8. USER'S SETTINGS LIST | 33 |
| 9. TECHNICAL DATA | 34 |

Explanation of symbols used in the manual:



- This symbol denotes especially important guidelines concerning the installation and operation of the device. Not complying with the guidelines denoted by this symbol may cause an accident, damage or equipment destruction.

IF THE DEVICE IS NOT USED ACCORDING TO THE MANUAL THE USER IS RESPONSIBLE FOR POSSIBLE DAMAGES.

1. SAFETY NOTES



Prior to commissioning the system read the operating instructions thoroughly. Instructions contain important information on installation, use, and safety of the device. Failure to follow the instructions can lead to serious injuries or damage to the property may occur if the respective precautions are not taken.



WARNING:

- Only qualified staff should work on this device or in its vicinity. The staff must thoroughly be informed about all warnings and maintenance measures according to this operating instruction.
- To ensure the correct and safe operation of this device, proper transport, storage and assembly as well proper operation and professional maintenance is required.
- TechWind disclaims responsibility for property damage or personal injuries resulting from installation or operation of the equipment by unprofessional or untrained personnel or improper use thereof. TechWind warns that improper installation may cause serious body injuries or property damage.
- TechWind reserves the right to modify the product to improve its functionality and quality. Always check if the version of the manual used by your or your personnel corresponds to the version of controller being installed or operated.
- Checking for visible signs of the transportation-related damage is mandatory before installation.
- Any unauthorised modification of hardware or software of the controller is not permitted.
- Do not power the unit from power sources of different ratings than described in the following chapters of this manual.
- It is mandatory to power down the whole unit prior to the controller installation.
- The entire wiring should be done and checked by the qualified installers with the valid certification according to the electrical regulations.



- Once installation is finished all connections should be re-checked.
- Usage of the controller without calibration and without entering proper door parameters is not allowed. The default parameters are not universal and will not provide optimal conditions of door operation. Specifically compliance with regulations related to the maximum kinetic energy cannot be achieved without entering correct door characteristics

2. INTRODUCTION

SDK-500 is an electronic controller of automatic elevator door. It ensures optimum operating conditions for doors of up to 400 kg. It was designed to work with drives fitted with shaft encoders powered with 5V DC, which generate from 150 to 999 pulses per centimetre of linear door motion.

Device automatically calculates door motion parameters (e.g. speed profile, acceleration and deceleration points, acceleration values) based on the door physical characteristics (weight and width) such as to ensure optimum operation of the drive.

Because of large value of allowable input currents, there are new menu options. Beside parameters corresponding to door weight and door width, it is important to set correct values of tightening force and reverse force. Incorrect settings (too high) of current value corresponding to tightening force may cause damage to the motor.

SDK-500 menu allows for setting of the current corresponding to tightening force - separately for open door and closed door positions. It is also possible to zero the tightening force while elevator is stopped (menu option: tightening force while **{CLOSE INP.}** signal – if it is supported by elevator's main controller).

Once the automatic calibration routine is completed, the calculated settings are stored in non-volatile memory of the controller. The **SDK-500** controls the door drive such as to meet the requirements of norms regulating the maximum driving force and the maximum kinetic energy of the door. Thanks to continuous monitoring of the drive parameters the **SDK-500** can detect increasing motion friction of the drive and alert the service person that maintenance is required.

All important operation information is presented in a clear manner on the built-in, backlit LCD display.

The **SDK-500** ships in a metal housing that ensures protection against mechanical damage as well as adverse environmental conditions.



INFORMATION:

Should you require more information, or should particular problem occur which are insufficiently described in that manual, please contact TechWind company.

tel. (+48 58) 684 86 19-20, fax (+48 58) 684 86 17

www.techwind.pl, e-mail: biuro@techwind.pl

3. CONTROLLER INSTALLATION



WARNING:

- Read the basic safety requirements on page 4 prior to starting the installation.
 - Ensure that the power supply network voltage corresponds to the nominal voltage stated on the unit's identification label.
 - Power supply terminals and other parts posing hazard of electric shock must be protected from unauthorised access
-

3.1. INSTALLATION

Install the controller such as to minimize the length of electrical connections between the controller and the motor / encoder unit. Use the four mounting holes in the base of the controller housing to secure the device in its mounting position.

Select mounting position for the controller such as to minimize the risk of inadvertent stepping onto its housing by elevator service personnel, but to ensure easy access to LCD display and keypad.

3.2. ELECTRICAL CONNECTIONS



WARNING:

- It is strictly required to provide good grounding of controller metal housing and transformer cover, using separate grounding wire to appropriate grounding terminal.
 - Motor and encoder wires must be shielded, and firmly fixed to door mounting frame in order to avoid mechanical damage to the wiring.
 - The ground plane of the controller's electronics **is electrically connected** to the housing.
-

Pay special attention to installation of the mains transformer. It is best to install it within the housing of the service ride switchboard usually found on top of the car. It is also possible to power the controller from an external DC power supply having appropriate current rating. If complete electrical isolation of the controller from the rest of the elevator's control system is required, use the transformer and use potential-free contacts of relays to drive the control inputs of the controller (see fig. 3.5A)

Figure 3.1 shows all external connectors of **SDK-500** controller. Connectors of optical barrier, relay outputs, control inputs and communication interface of RS-485 are located near the LCD display and keyboard area.

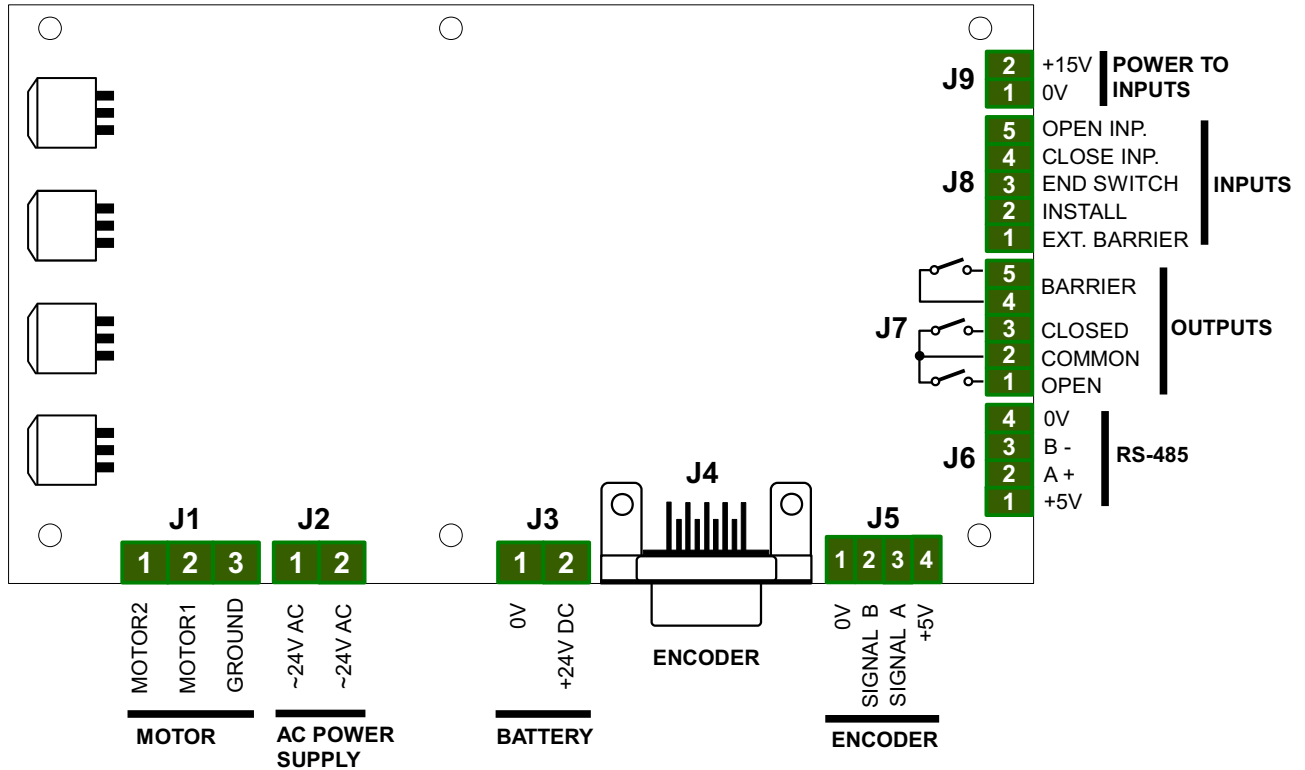

Fig. 3.1. Connectors of **SDK-500** controller

3.3. POWER SUPPLY

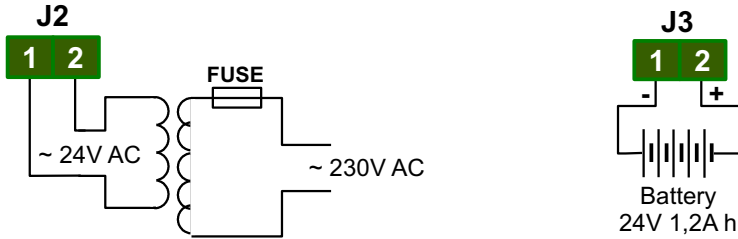

Fig. 3.2. Power supply connection of **SDK-500** controller

Main power is supplied by a toroidal transformer - minimum 150VA and nominal output voltage 24VAC.



- It is necessary to protect the transformer primary winding circuit with a 2A fuse.
- Never use transformers having idle secondary voltage higher than 27 VAC

If door operation is required also during mains failure a 24V battery of minimum 1.2Ah capacity must be connected externally. Use of two standard 12V batteries connected in series is possible. An automatic battery charger circuitry is a part of the controller board and is designed to charge battery with 200 mA current, which is sufficient to keep the battery fully charged, but will not be able to quickly charge fully discharged batteries. If main power supply fails then LCD backlight and motor will be switched off and **SDK-500** will continue operating on battery. When the battery voltage drops below certain threshold (19V) the controller will shut down.

Battery connection is not mandatory and the controller can operate normally without it, however the battery voltage read-out on the LCD will be displayed incorrectly.

3.4. MOTOR

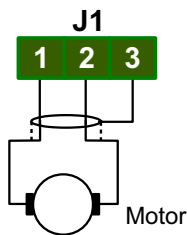

Fig. 3.3. Motor connection of **SDK-500** controller

The motor should be connected to **SDK-500** using shielded 2-wire cable. Make sure that shield is connected properly to GND at one end only. Leaving shield disconnected may cause excessive EMC noise. See chapter **First power-on** on page 29 to check the order of wire connections.

3.5. ENCODER

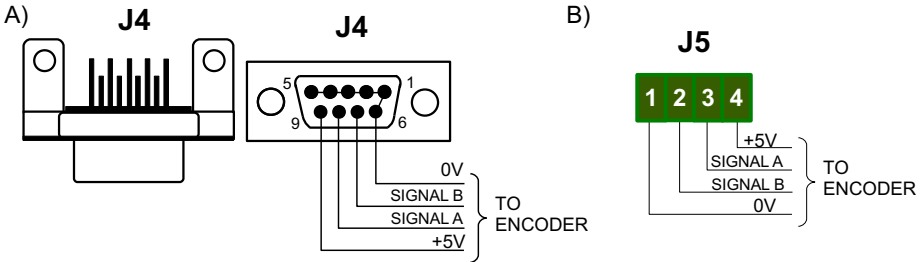

Fig. 3.4. Encoder connection of **SDK-500** controller

The controller is designed to work with motors equipped with 5V quadrature encoders, generating from 150 to 999 pulses per centimetre of door's linear movement. Typically encoder cables are terminated with a Canon DB-9 connector. The **SDK-500** has a DB-9 socket on board in order to facilitate fast and convenient installation. (Figure 3.4 A).



CAUTION! Make sure that encoder signal pins match **SDK-500** encoder connector to avoid damage to the controller.

If the encoder cable is not terminated with Canon DB-9 connector, the encoder can be connected directly to the **SDK-500** board's screw terminals as shown in figure 3.4B.

3.6. CONTROL INPUTS

The **SDK-500** controller is equipped with two control inputs provided for compatibility with different types of elevator controllers. Both inputs or either of them individually can be activated from the menu of the controller. Connection alternatives are shown below.

Figures 3.5 A and B shows how to connect open/close control signals to **{CLOSE INP.}** and **{OPEN INP.}** inputs of the **SDK-500**. The control signals are generated by the main controller of the elevator. If the elevator control system uses normally-open potential-free contacts (e.g. relay) to control the doors they can be connected to **SDK-500** as shown in fig. 3.5A utilising the on-board voltage source of the controller. If the elevator control system uses voltage outputs to control doors, they can be connected to **SDK-500** as shown in fig. 3.5B. Make sure that both inputs are activated in the controller's menu.

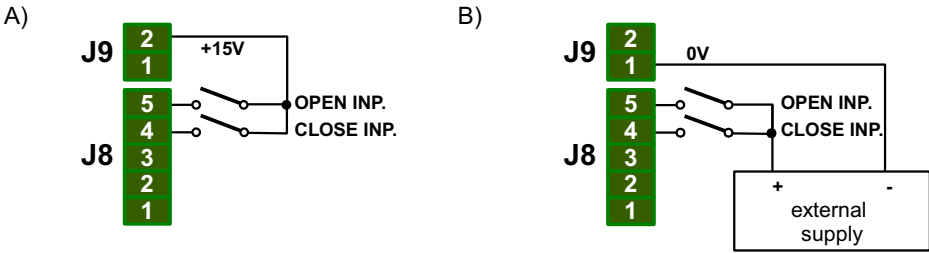

Fig. 3.5. Connection of the controller while using both inputs

Application of voltage to the **{OPEN INP.}** input will make **SDK-500** start the door opening procedure. During that, until the door is fully open (until the **{OPEN}** relay output is active) removal of the voltage from **{OPEN INP.}** input will cause the **SDK-500** to reverse the door movement in order to close it. Removal of the voltage from **{OPEN INP.}** input after the door has fully opened will not initiate the closing procedure and the door will remain open.

Application of voltage to the **{CLOSE INP.}** input will make **SDK-500** start the door closing procedure. During that, until the door is fully closed (until the **{CLOSED}** relay output is active) removal of the voltage from **{CLOSE INP.}** input will cause the **SDK-500** to reverse the door movement in order to open it. Removal of the voltage from **{CLOSE INP.}** input after the door has fully closed will not initiate the opening procedure and the door will remain closed.

Voltage should not be applied to both control inputs at the same time. If it is, however, the **{CLOSE INP.}** signal wins and the **SDK-500** will behave as if only voltage was applied to **{CLOSE INP.}** input.

Figures 3.6 A and B shows how to connect the control inputs in systems where only one output is used by the main elevator controller to control door's opening and closing. Figure 3.6A shows how to connect the **{OPEN INP.}**, input using internal **SDK-500** voltage source and figure 3.6B shows connection in case of using voltage output on the elevator's main controller.

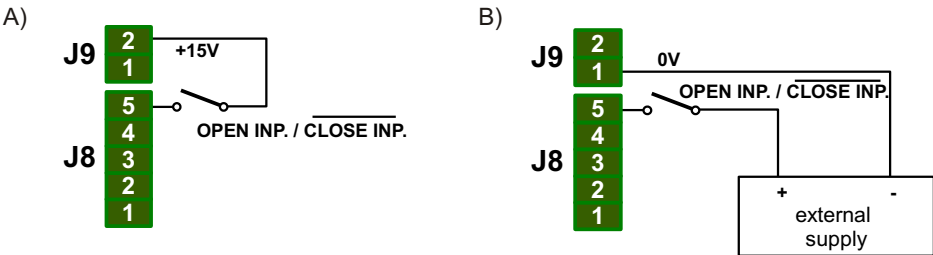

Fig. 3.6. Connection of the controller while using single **{OPEN INP.}** input

Make sure that **ONLY** one input - **{OPEN INP.}** - is activated in the menu of **SDK-500** for this type of control. In this mode, if the voltage is applied to the **{OPEN INP.}** input, **SDK-500** will open the door and keep it open as long as the voltage remains applied. Removal of the voltage from the **{OPEN INP.}** input will make the controller close the door.

Although the **SDK-500** can also be controlled using **{CLOSE INP.}** input only as shown in fig. 3.7 A and B. For this purpose only the **{CLOSE INP.}** input must be activated in the controller's menu. In this case the application of voltage to **{CLOSE INP.}** input will make the

controller to close door and keep it closed. Removal of voltage will make the controller to open the door. Therefore this control variant is **NOT RECOMMENDED** for **SAFETY REASONS**. Even momentary drop of voltage on the **{CLOSE INP.}** control input will immediately start door opening procedure and, as a result, opening of safety interlock circuitry of the elevator.

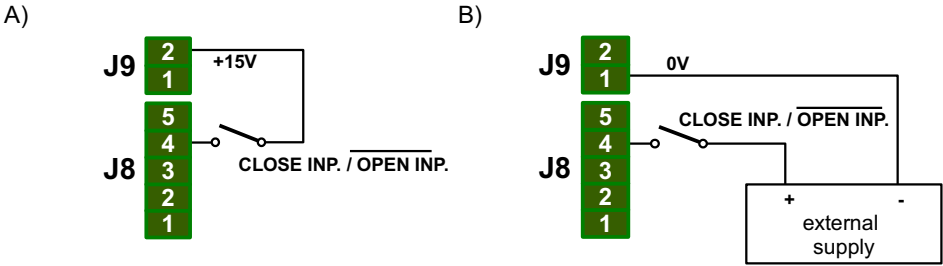

Fig. 3.7. Connection of the controller while using single **{CLOSE INP.}** input

3.7. RELAY OUTPUTS

The **SDK-500** controller is equipped with three normally-open relay outputs. Two of them (**{OPEN}**, **{CLOSED}**) indicate the door reaching the terminal positions (fully open or fully closed). The third one (**{BARRIER}**) is used to indicate detection of an obstacle during the door movement. It is activated both in case of the optical barrier interruption as well as in case of a mechanical blocking of the door movement.

Note that the relay outputs operation depends on the menu option settings. Figure 3.8 shows connection of relay outputs and inductive loads. In this case it is required to use additional suppression circuit (typically capacitor 47nF/ min. 250VAC in series with 100R/5W resistor), connected in parallel to relay terminals or (better) directly on the load (see figure 3.8). In consequence of using the suppression circuit, the level of generated electromagnetic disturbances is lower, and the life of relay contacts rises.

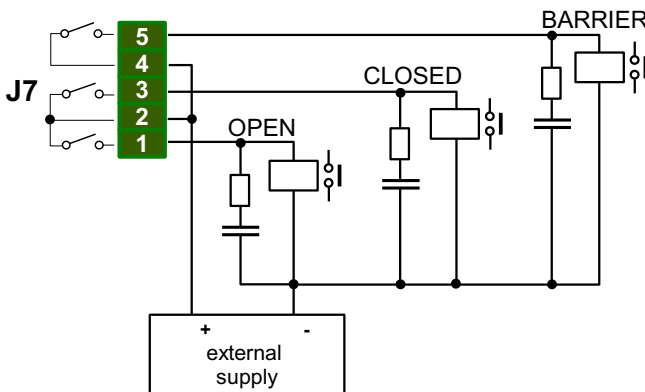

Fig. 3.8. Relay outputs connection of **SDK-500** controller

3.8. EXTERNAL OPTICAL BARRIER

Typically optical barriers and optical detectors are connected into the main elevator controller. In order to speed up system reaction to interruption of the barrier, connect the barrier signal directly to **SDK-500**.

Connections of external optical barrier is shown in fig. 3.9A – using internal voltage source of **SDK-500** and in fig. 3.9B - using external voltage from the main controller unit or from the external optical barrier power supply.

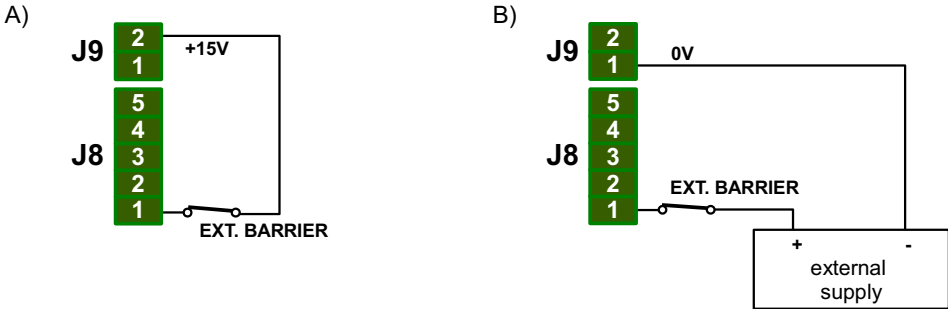

Fig. 3.9. External optical barrier connection



CAUTION!

- With the barrier not interrupted the voltage must at all times be applied to the **{EXT. BARRIER}** input.
- Remember to activate external barrier in the controller's menu (see **External** parameter description at page 24) .
- Remember to properly select operation options of the **{BARRIER}** relay output in the controller's menu (see **BARRIER out.** parameter description at page 24).

3.9. INSTALL SWITCH

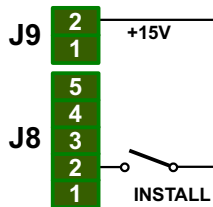

Fig. 3.10. Install switch connection

Figure 3.10 shows connections of an Installation switch to **{INSTALL}** input of the **SDK-500**. The Installation switch can be mounted on the housing of the **SDK-500** in order to perform „*Installation*” procedure without the need to enter the controller's menu. If the **{INSTALL}** input is activated for a few seconds the **SDK-500** will enter the „*Installation*” procedure (see page 19).



CAUTION!

- Before **{INSTALL}** switch can be used, the door parameters must be entered to the controller using menu.
- **{INSTALL}** input is enabled by default.

3.10. OPTIONAL TERMINAL POSITION CONTACT (DOOR OPEN)

Figure 3.11 shows the connection of the optional terminal position contact (NO type contact connected to the **{END SWITCH}** input) to indicate the full opening of the door. Use of such contact is optional as the **SDK-500** detects the terminal positions of door by detecting the mechanical resistance at its terminal positions. This **{END SWITCH}** input is provided for compatibility of **SDK-500** with the widest range of doors and control systems.

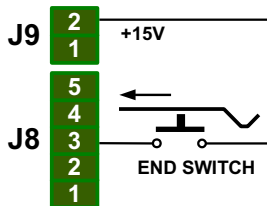

Fig. 3.11. Optional terminal position contact connection



CAUTION!

Remember to activate **{END SWITCH}** input in the controller's menu (see **OPEN switch** parameter description at page 21).

3.11. OPTIONAL RS-485 INTERFACE

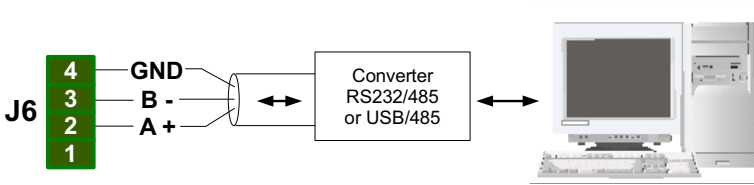

Fig. 3.12. RS-485 interface connection of **SDK-500** controller

Figure 3.12 shows the connections of the RS-485 communication interface used for connecting the **SDK-500** with other elevator controller products from TechWind. The following functions are available via the RS-485 interface:

- open/close door control
- continuous current consumption monitoring
- momentary door speed read-out
- detailed information about current door position
- monitoring of mechanical resistance during the door movement
- controller parameters read

3.12. EMERGENCY BATTERY POWER SUPPLY BUTTON



[RUN ON BATTERY] button allows to switch on the emergency battery power supply.

The **SDK-500** controller is equipped with the input for back-up battery power supply connection. It allows the controller to continue operation and open the door in the case of mains failure. To prevent damage to the battery, **SDK-500** will automatically shut down and disconnect the battery after battery voltage drops below certain level (19V) or door is fully open, but not earlier than 30 sec. after last keyboard use. Every keyboard use cause to extend run on battery by next 30 seconds. In order to resume the **SDK-500** operation on battery power, press the **[RUN ON BATTERY]** button located on the front panel of the controller housing (on the right side of LCD display).

4. CONTROLLER PROGRAMMING

The programming menu allows the installer to set all parameters of controller operations. The meaning of the particular parameters is described in chapter **MENU DESCRIPTION**.



- Be sure to read **First power-on** section before first powering the **SDK-500!**
- Entering the menu is achieved by pressing and holding for 3 seconds **[ESC/MENU]** button. In case the password was entered (see **Access pass.** description at page 25), the first message will be **"Enter Password"** message. Entering the programming menu stops the motor.

4.1. PROGRAMMING MENU

To enter main menu operator must to press and hold at least 3 sec. **[ESC/MENU]** button. If the user password is defined (see parameter „**Access pass.**“, menu „**Access setup**“), operator have to enter correct one before proceeding to menu options. Entering of the passwords is similar to the edition of numeric parameters. After entering of last digit of the password first menu position will be displayed (if the password is correct) or **"Wrong password!"** message otherwise.

Functions of the buttons while sub-menu and parameters choice:



Buttons [**<**] [**>**] allows to choose particular menu option and change value of selected parameter. Display shows the name of selected item or its value.



Functionality of **[ENTER]** button depends on present menu position:

- If selected menu position is a parameter, pressing this button allows to edit its value.
- If selected menu position is a sub-menu, pressing this button will enter the sub-menu and show the first of its options.



- The **[ESC/MENU]** button allows to leave current sub-menu and abandon changes. If pressed in the main menu it will make **SDK-500** exit the programming mode and resume normal operation.
- Pressing and holding down **[MENU/ESC]** for 3 seconds in normal state of the controller to enter the programming menu.

4.2. EDITING PARAMETERS

To edit any of the programming parameters select its name using [**<**] [**>**] buttons and press [**ENTER**].

4.2.1. Numeric parameters

Numeric parameters are displayed as decimal numbers. Use buttons [**<**], [**>**] to increment or decrement selected (flashing) digit. Short pressing of the [**ENTER**] button moves the selection to next digit.

Pressing [**ENTER**] at least 2 seconds (or pressing short after last digit) causes in displaying confirmation question (message "**Save changes?**"). Select the answer („**YES**" or „**NO**") using [**<**], [**>**] buttons and confirm selection by short pressing [**ENTER**] button.

4.2.2. Switch parameters

Switch parameters can be described as a sets of values (a lists) out of which only one of the options available on the list can be selected for the given parameter. Options of switching parameter are selected using [**<**], [**>**] buttons.

Short pressing of [**ENTER**] displays confirmation question (message "**Save changes?**"). Select the answer („**YES**" or „**NO**") using [**<**], [**>**] buttons and confirm selection by short pressing [**ENTER**] button.

Functions of buttons when editing numeric and switching parameters



While editing numeric parameters – change of current (flashing) digit. While editing switch parameter – selection of switch parameter.



If numerical parameter is being edited, a short press of [**ENTER**] button change edited position. A long press of [**ENTER**] button (at least 2 sec.) causes of display a "**Save changes?**" ask. If switch parameter is being edited, a short press of [**ENTER**] button causes of display a "**Save changes?**" ask. Pressing [**ENTER**] button again (while "**Save changes?**" is displayed) the answer selected by [**<**], [**>**] buttons is confirmed.



Abandon entered (not confirmed) changes and go back to menu.

4.3. MENU STRUCTURE

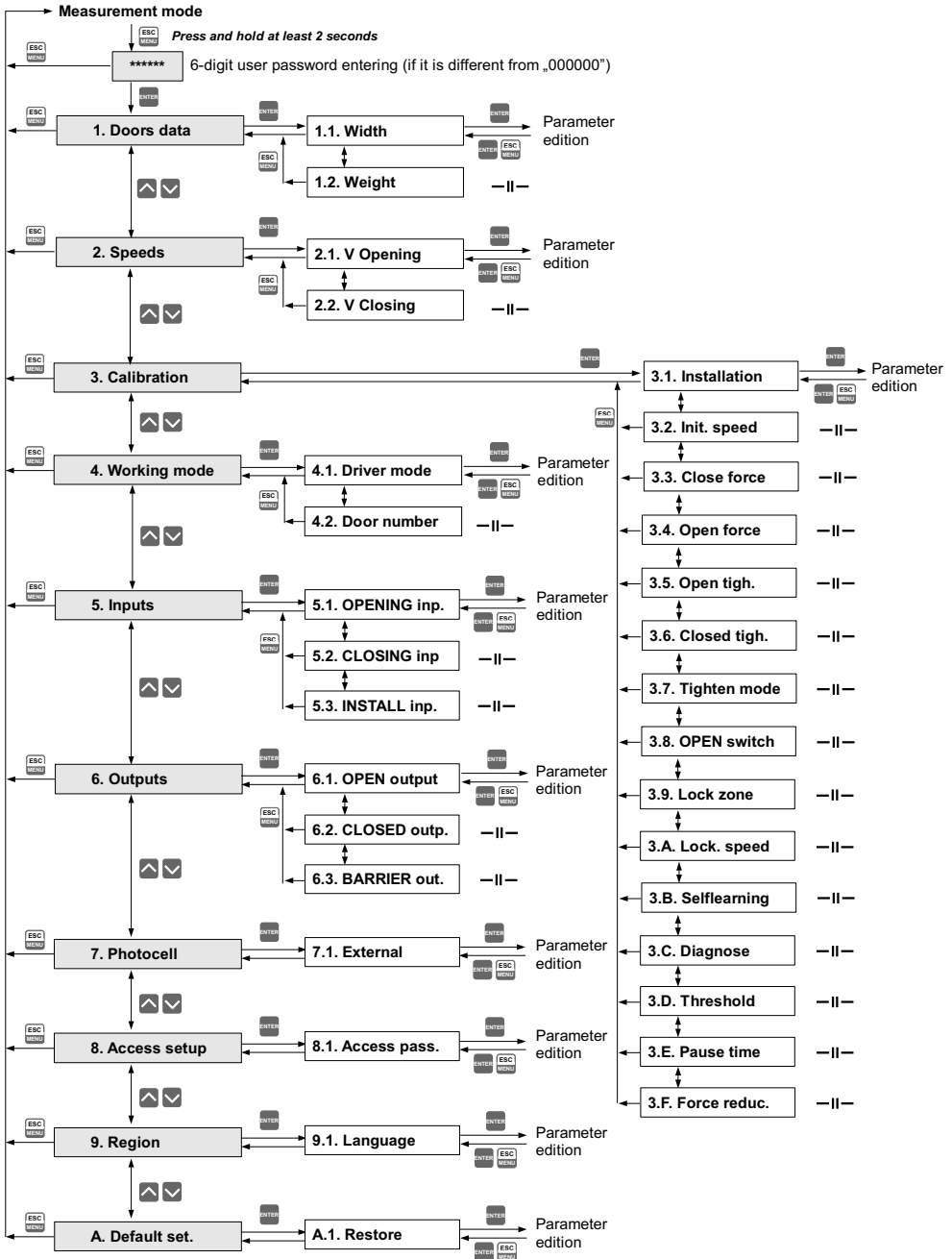

4.4. MENU DESCRIPTION

1. Doors data

1.1. Width, range: 20.0 ÷ 399.9 [cm]

The real (measured) path of a single-slide of door must be entered here. For single-slide door the entire door width must be entered. For double slide door (build with two separate parts meeting in the centre) a half of the entire door width must be entered. Entering incorrect value will lead to incorrect calculation of the real door speed, which is necessary to stay in line with value entered to the menu.

1.2. Weight, range: 10 ÷ 399 [kg]

It is mandatory to enter real door weight. It is critical to control of door's kinetic energy, whose maximum value must not exceed 10 J.



- **CAUTION!** Entering incorrect values can lead to the faulty operation of the door and/or can create serious risk of injuries.
- If the door weight setting is being changed after the speed settings have been made and a value is entered which would result in exceeding the maximum allowable kinetic energy of the door, the controller will display "**Kinetic energy exceeded**" message and automatically adjust maximum speed such as to account for the new weight setting.

2. Speeds

2.1. V Opening, range: 0.10 ÷ 0.79 [m/s]

Required door opening speed should be entered here.

2.2. V Closing, range: 0.10 ÷ 0.79 [m/s]

Required door closing speed should be entered here.

Based on the entered door weight **SDK-500** automatically calculates maximum door speed not to exceed the maximum allowed kinetic energy of the door (10J). If the **V Opening** or **V Closing** entered here is greater than the calculated maximum speed, it will be adjusted down to prevent of exceeding the maximum value of kinetic energy.



- If the door weight setting is changed by the installer (operator) such that the kinetic energy calculated for speed **V Opening** or **V Closing** exceeds the permissible value then "**Kinetic energy exceeded**", message is displayed. In this case adjustments are made automatically to **V Opening** or **V Closing** or both to bring the kinetic energy down to its maximum value.
- **CAUTION!** Subsequent change of door weight setting back to original value **WILL NOT** affect the **V Opening** or **V Closing** values. It is necessary to enter required values again.



- If the door weight setting is being changed after the speed settings have been made and a value is entered which would result in exceeding the maximum allowable kinetic energy of the door, the controller will display "**Kinetic energy exceeded**" message and automatically adjust maximum speed such as to account for the new weight setting.
-

3. Calibration

3.1. Installation [execute]

The „**Installation**” procedure must be performed during the first power-on of the **SDK-500** controller. The door will be driven slowly to fully closed position and then to fully open position.



If start of „**Installation**” procedure causes door opening it is important to stop procedure immediately by pressing [**ESC/MENU**] button. Next switch off the controller power supply and swap motor power supply lines – **J1.1** and **J1.2** connectors (see figure 6.1 at page 29). After changing motor power supply connection „**Installation**” procedure must be start again.

During this movement terminal positions of the door will be identified and stored in the controller's non-volatile memory. Then the door will be closed again. Finally, door will open and close three times with programmed speeds and entered values of the door parameters. During that operation an average current value will be stored in the controller's non-volatile memory as the reference values for the door mechanical resistance.

Installation procedure should only be executed when all door parameters are correctly set in the **SDK-500**. This procedure is set of two procedures executed in sequence: „**Selflearning**” procedure (described at page 22) and „**Diagnose**” procedure (described at page 22).

3.2. Init. speed (Initialisation speed), range: 5,0 ÷ 99,9 [%]

Percentage value of the door speed during initialisation and calibration process should be entered here.



If value entered by user will be too high, then calibration may fail.

3.3. Close force (Closing force), range: 0.00 ÷ 6.00 [A]

In this menu the static door closing force is entered, expressed as the corresponding motor current in Amperes. In order to determine it, during the calibration use a dynamometer to find the current corresponding to the force of 150 N, which the regulations adopt as the maximum permissible static force applied by the door to any object in its path. The corresponding current value is treated by the controller as the absolute maximum current to be supplied to the motor while door closing.

3.4. Open force (Opening force), range: 0.00 ÷ 6.00 [A]

In this menu the static door opening force is entered, expressed as the corresponding motor current in Amperes. In order to determine it, during the calibration use a dynamometer to find the current corresponding to the force of 150 N, which the regulations adopt as the maximum permissible static force applied by the door to any object in its path. The corresponding current value is treated by the controller as the absolute maximum current to be supplied to the motor while door opening.



- If the door encounters an obstacle in its path, the motor's current consumption rapidly increases. If it exceeds the value set by „**Close force**” or „**Open force**” parameters the controller will stop the door and reverse its motion to move it away from the obstacle.
 - Once the door is moved away from the obstacle, the controller will attempt to close/open the door once again. If the obstacle is still in the door's way, the procedure will be repeated up to 5 times. If the obstacle is still in the door's way the controller will attempt to close/open the door moving it at minimum speed. If this attempt also fails, the controller will move the door to fully open/closed position and wait for 20 sec. Next the closing/opening procedures starts again. If {OPEN INP.}/{CLOSE INP.} signals will change while attempt of closing/opening procedure then full cycle will start again.
-

3.5. Open tigh. (tightening force of opened doors), range: 0.00 ÷ 1.00 [A]

The value of the current used to tighten door at its open positions. This value should be determined empirically by taking into account all forces from mechanical closing elements like springs and weights. Before changing this parameter, door should be closed. Then increase current value carefully to cause the door moving slowly into fully open position. If door stops during opening then continue increase current to force moving. Final current should be set to lowest value to keep door in fully open position.



- During current setting procedure, door speed is NOT controlled – therefore to avoid door crash do NOT set high current values. Current value should be increased very carefully, very slow, with visual door motion control. When door is moving (opening), do NOT increase the current value.
 - Do not set current value greater than determined during procedure described above. To high current value may cause motor overload, overheat and even damage.
-

3.6. Closed tigh. (tightening force of closed doors), range: 0.00 ÷ 1.00 [A]

The value of the current used to tighten door at its closed positions. This value should be determined empirically by taking into account all forces from mechanical closing elements like springs and weights. Before changing this parameter, door should be open. Then increase current value carefully to cause the door moving slowly into fully closed position (and locks - if available - will be closed). Final current value should be set to value enough to avoid door opening and/or opening the locks, and to avoid manual door opening with ease.



- During current setting procedure, door speed is **NOT** controlled – therefore to avoid door crash do **NOT** set to high current value. Current value should be increased very carefully, very slow, with visual door motion control. When door is moving (opening), do **NOT** increase the current value.
- Do not set current value greater than determined during procedure described above. o high current value may cause motor overload, overheat and even damage.

3.7. Tighten mode, options: [continue / by CLOSING input]

„**Tighten mode**” setting determines when tightening force (set by „**Closed tigh.**”) is used. Available options:

„ **continue** ” - closed door is tighten continuously (power supply of motor is always on),

„**by CLOSING input**” - closed door is tighten only if voltage is provided to the **{CLOSE INP.}** input. Removal of the voltage from **{CLOSE INP.}** input causes turning off the power supply of motor (about 5 minutes after removing voltage from **{CLOSE INP.}** input).

3.8. OPEN switch, options: [inactive / active]

Open switch (terminal position contact) is an additional optional switch often mounted in sliding doors. It should activate **{END SWITCH}** input at door's fully open position (see figure 3.11 at page 13). Its usage is optional as the controller automatically detects the terminal positions of the door by detecting mechanical resistance (by measuring the current consumed by the motor). Open switch activation causes holding door in fully open position using „**Open tigh.**” parameter value (tightening force of open door).

3.9. Lock zone, range: 0.0 ÷ 29.9 [cm]

When door reaches fully closed position, its mechanism still continues its motion to lock it in position. To ensure smooth door movement (especially during door opening), the lock zone value should be set equal or greater than the real (physical) lock zone length.



- Failure to set the lock zone properly may cause faulty operation of heavy doors (200kg and above).
- **CAUTION!** It is important to remember that for new controllers default value of the lock zone is equal to 4 cm. Please remember to enter the correct value. For doors without lock zone the value should be 0.

3.A. Lock. speed, range: [MIN, 20%, 40%, 60%, 80%, 100%]

Required speed of the door locking should be entered here. MIN = 2.5 cm/s, speed of door locking for option 100% depends on lock zone length.

3.B. Selflearning [execute]

During the „**Selflearning**” procedure the controller will move the door from the fully open position to the fully closed position (at low speed). During such a move all pulses are calculated and stored into the controller memory. Counted pulses represent door width.



There is no need to enter any characteristic points of the door speed profile as **SDK-500** controller calculate these points automatically adjusting all movement parameters for optimal door functionality. All parameters are set according to meet regulations.

3.C. Diagnose [execute]

It is recommended to execute the „**Diagnose**” procedure on the new installation or after door mechanism maintenance. **SDK-500** will perform closing procedure three times and will remember average current value during this operation which will be stored as a reference value for „**Threshold**” parameter. During operation dirt and mechanical factors will cause additional movement resistance which will influence the current value. As the controller is monitoring current has a chance to detect and signal maintenance need.

3.D. Threshold, range: 0 ÷ 99 [%]

This parameter defines permissible percentage by which the average current value may be exceeded during opening+closing cycle. This threshold value is stored in memory during door installation or periodic door maintenance visit by the installer. Maintenance value of current I_M can be calculated using formula:

$$I_M = I_{AV} [mA] \times \frac{100 \text{ Threshold} [\%]}{100}$$

where I_{AV} - average current value of opening+closing cycle stored in memory while installation or periodical door mechanism maintenance

If average current value of opening+closing cycle is greater than maintenance value of current I_M then present screen of the LCD display will be shown alternately with „**Need service**” message.

3.E. Pause time, range: 0 ÷ 29 [s]

This parameter determines the delay of the automatic closing of the door when opened manually.



If, during the delay "**Pause time**", the door will be opened by hand to the width of more than 5 cm, the engine is switched off and switched back on after a delay.

3.F. Force reduc. (Force reduction), range: 0 ÷ 99 [%]

This parameter determines the percentage reduction in force at the ends of the door.

4. Working modes

4.1. Driver mode, options: [RS-485 lines / external inputs / automatic / manual]

The **SDK-500** controller is designed as a universal unit to be used with various 3rd party elevator control systems. To provide proper connection to different types of main controllers, correct menu option must be chosen:

- „ **RS-485 lines** ” - systems control using RS-485 communication bus and ModBus RTU protocol. It is required to provide proper data transmission format and registers addresses.

- „ **external inputs**” - systems control using separate **{CLOSE INP.}** and **{OPEN INP.}** inputs.

- „ **automatic** ” - automatic closing and opening option is used for service purposes only. It allows for automatic opening and closing door. Once it is selected doors are opening and closing every 5 second ignoring any external signals.

- „ **manual** ” - after setting this option and leaving the menu, each **[ENTER]** pressing will close and open doors alternately.

4.2. Door number, range: 0 ÷ 3

Used in multi-door installation. It corresponds to the address of the **SDK-500** controller and is used in systems driven by RS-485 interface **ONLY**.

5. Inputs

5.1 OPENING inp. (OPENING input), options: [inactive / active]

Voltage controlled input. Receives signals from the main elevator controller. If **{OPEN INP.}** input is set to 'active', then signal on this input will open the door. If **{CLOSE INP.}** input (see “**CLOSING inp.**” parameter description) is set to 'inactive', then removing the signal will close the door.

5.2 CLOSING inp. (CLOSING input), options: [inactive / active]

Voltage controlled input. Receives signals from the main elevator controller. If **{CLOSE INP.}** input is set to 'active', then signal on this input will close the door. If **{OPEN INP.}** input (see “**OPENING inp.**” parameter description) is set to 'inactive', then removing the signal will open the door.



It is not advisable to set **{OPEN INP.}** to inactive and **{CLOSE INP.}** to active. Such settings may cause malfunction of the door if electrical wiring of these inputs becomes damaged.

5.3. **INSTALL inp.** (*INSTALL input*), options: [*inactive / active*]

If the menu option "**INSTALL inp.**" is set to active, then applying voltage to **{INSTALL}** input will automatically perform installation procedure (see „**Installation**” option at page 19).

6. **Outputs**

SDK-500 controller has 3 relay outputs (**{OPEN}**, **{CLOSED}**, **{BARRIER}**) used to feed control signals to the elevator control system.

6.1 **OPEN output**, options: [*inactive / normal open / normal closed*]

The relay connected to the output is not controlled when this option is set to *inactive*. If set to *normal open* the relay will be in the closed state after the full door opening. If set to *normal closed* the relay will be open after the full door opening.

6.2 **CLOSED outp.**, options: [*inactive / normal open / normal closed*]

The relay connected to the output is not controlled when this option is set to *inactive*. If set to *normal open* the relay will be in the closed state after the full door closing. If set to *normal closed* the relay will be open after the full door closing.

6.3 **BARRIER out.**, options: [*inactive / normal open / normal closed*]

The relay connected to the output is not controlled when this option is set to *inactive*. If set to *normal open* the relay will be in the closed state after the the photo barrier activation or mechanical obstacle detection on the way of the door. If set to *normal closed* the relay will be open after the photo barrier activation or mechanical obstacle detection on the way of the door.

7. **Photocell**

This menu allows for sending signals from the optical barrier to the **SDK-500**. When optical barrier is not connected to the door controller, all options must be set as inactive.



CAUTION! Incorrect setting of the optical barrier working mode can cause improper work, for example very slow closing after long waiting time.

7.1 **External**, options: [*inactive / transfer / active*]

This parameter defines working mode of **SDK-500** and external optical barrier connected to **{EXT. BARRIER}** input. It is necessary to transfer optical barrier signal using normally closed contact (see figure 3.9 at page 12). Available working modes:

- „ **inactive** ” - **{EXT. BARRIER}** input is inactive,
- „ **transfer** ” - in this mode **{EXT. BARRIER}** input signal is transferred to **{BARRIER}** output only (see **BARRIER out.** option at page 24). **SDK-500** do not process **{EXT. BARRIER}** input signal.

„ **active** ” - in this mode **{EXT. BARRIER}** input signal is transferred to **{BARRIER}** output and **SDK-500** process **{EXT. BARRIER}** input signal. Activation of **{EXT. BARRIER}** input (open contact) causes door opening immediately – regardless of **{OPEN INP.}** and **{CLOSE INP.}** input signals.



CAUTION! The door controller retries closing door attempts when the optical barrier signal **{EXT. BARRIER}** disappears. Optical barrier state testing and closing retries every 3 seconds. The door controller tries to close the door 5 times. If all 5 tries are unsuccessful, controller tries once more moving the door with minimal speed and ignoring optical barrier signals. During this operation however the possibility of mechanical obstruction is being checked.

8. Access setup

8.1. Access pass. (Access password), range: 000000 + 999999

Setting the password to 000000 allows free access to the menu. Once any other password is selected and stored it will be asked each time the menu is started.



There is no way to recover a lost password by the user or installer. In such event please contact TechWind for assistance

9. Region

9.1. Language, options: [Polish, English]

Language of the controller menu content.



SDK-500 is only capable of simultaneously having two language versions of the menu. The default languages for the Polish market version are Polish and English. Please contact TechWind about other language versions

A. Default set.

A.1. Restore [execute]

„**Restore**” command allows to return all settings to their factory defaults. The description of the factory default settings is included in the menu described in this manual.



CAUTION! Restoring all values to the factory defaults will overwrite all settings including any door/drive parameters. All initialisation and calibration procedures have to be repeated as described in **First power-on** chapter.

5. MESSAGES



CAUTION! The last characters in either of the two lines is used for diagnostic purposes and have following meaning:

Upper line, rightmost character:

_ (underscore) - **{OPEN INP.}** input state is low

^ - **{OPEN INP.}** input state is high

Lower line, rightmost character:

_ (underscore) - **{CLOSE INP.}** input state is low

^ - **{CLOSE INP.}** input state is high

5.1. NORMAL OPERATION

Following screens are available during the normal operation:

SCREEN 1

line1: producer name;
line2: door state information (initialisation, open, closed, opening, closing, retreat) or encoder failure message;

Opening < >

Closing > <

Door is open

Door is closed

Initialization

Encoder failure

SCREEN 2

line1: door speed in m/s
line2: current value in A

Speed: 0.35m/s
Current: 2.15A

SCREEN 3

line1: door position in cm
line2: pulses counter value

Posit.: 67cm
Counter: 30150

SCREEN 4

line1: average current value of opening+ closing cycle in A
line2: maximal current value of opening / closing operation in A

av. cur.: 0.50A
m. cur.: 2.10A

SCREEN 5

line1: power supply voltage in V
line2: battery power supply in V

Power: 24.0V
Battery: 21.3V

SCREEN 6

line1: tightening force (current) of closed door in A
line2: A
tightening force (current) of open door in A

Tight.c: 0.30A
Tight.o: 0.60A

SCREEN 7

line1: door closing current (force) in A
line2: door opening current (force) in A

C.force: 2.00A
O.force: 2.80A

SCREEN 8

line1: present temperature of the controller executable components in °C
line2: permissible temperature of the controller executable components in °C

Temper.: 26`C
T. max.: 120`C

SCREEN 9

line1: control inputs state, in order: **{OPEN INP.}, {CLOSE INP.}, {END SWITCH}, {INSTALL}, {EXT. BARRIER}**
line2: relay outputs state, in order: **{BARRIER}, {CLOSED}, {OPEN}** and battery power supply switch state

Inputs: 00001
Outputs: 000 0

5.2. WARNING MESSAGES

While normal operation and menu parameters configuration some warning messages described below can appear on the display.

When motor driver is overheated the message „**Exceedance of temperature**” is displayed alternately to current screen.

Exceedance of
temperature

If the average current value of opening+closing cycle is higher than maintenance current value I_M (described at page 22) then present screen will be displayed alternately to the „**Need service**” message.

Need service

If the parameter „**Access pass.**” was set to the value other than 000000, then password is required before entering menu. There is „**Enter password**” message displayed to remind about it.

Enter Password

In case of wrong password entering „**Wrong Password!**” message is displayed.

Wrong Password!

In case your password is forgotten please contact TechWind to receive new – one use password. Once the one use password is entered the message „**Enter new password!**” is displayed. User must enter new password. This operation can not be omitted.

Enter new password!

All menu parameters have their range which can be entered. If the value out of range is entered „**Incorrect Value**” message is displayed and edit function is continued.

Incorrect Value

Controller checks the allowed limit of the maximum kinetic energy, once parameter „**Weight**”, „**V opening**” or „**V closing**” are changed in the menu. If the opening /closing speed is too high for the door weight then speed is automatically reduced to value corresponding to maximum allowed value of kinetic energy. ($E_{kmax} < 10J$). In such a case message „**Exceedance of kinetic energy**” and next „**Speed is decreased !**”

Exceedance of
kinetic energy

Speed is
decreased !

6. FIRST POWER-ON



Before the first power-on, please make sure that all electrical connections are made properly. Pay special attention to the motor and encoder connections. See **Controller Installation** section of this manual for further details.

Having made sure that all electrical connections to the controller are made properly, position the elevator's car such that the car's door latches on to the shaft's door. Please check that all mechanical parts of the transmission (guides, rollers, bearings) are in good condition. This is necessary for proper execution of the calibration procedure.

Before power up the controller slide the door into half-open position. After power up, the controller will display the welcome screen, containing the software version number, and „**Initialisation**“ message. Immediately after controller unpacking its parameters are set by default settings, which can be restored whenever using „**Restore**“ option in „**Default set.**“ menu.

To prepare **SDK-500** for working enter the menu of the controller by holding the **[ESC/MENU]** button for 3 seconds. Once in the menu, enter all parameters characterising the door, and its drive. See the **Controller programming** section at page 15 for details.



- **CAUTION!** Entering wrong parameters (i.e. not corresponding to actual door and drive characteristics) may cause malfunction of the door controlled by **SDK-500** and/or may pose significant danger to persons using the door.
- The controller uses the entered value of the door's mass and controls the speed such as to ensure that the door never exceeds the maximum allowed kinetic energy limit.

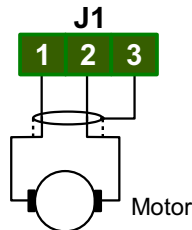

Fig. 6.1. Motor supply connector

When all parameters are set, please perform the „**Installation**“ procedure (see page 19). The door should be driven slowly to fully closed position and then to fully open position.



If start of „**Installation**“ procedure causes door opening it is important to stop procedure immediately by pressing **[ESC/MENU]** button. Next switch off the controller power supply and swap motor power supply lines – **J1.1** and **J1.2** connectors (see figure 6.1 at page 29). After changing motor power supply connection „**Installation**“ procedure must be start again.

During this movement terminal positions of the door will be identified and stored in the controller's non-volatile memory. Then the door will be closed again. Finally, door will open and close three times with programmed speeds and entered values of the door parameters. During

that operation an average current value will be stored in the controller's non-volatile memory as the reference values for the door mechanical resistance.

Once all procedures described above are finished, leave the controller's menu by pressing the **[ESC/MENU]** button. Again, the initialisation procedure will start automatically and the door will move to the closed position. You will see **"Door closed"** information on the display. The door and the controller are ready for normal operation.

7. RS-485 INTERFACE HANDLING (optional)

There is optional RS-485 used for communication with **SDK-500** controller. Transmission parameters:

- format: 1 start bit, 8 data bits, 1 or 2 stop bits, no parity control
- baud rate: 19200 bit/sec.,
- protocol: Modbus RTU,
- device address: $0x18 + N$ (where N means value of **"Door number"** parameter).

All device parameters are available via RS-485 interface, as HOLDING-type registers. The registers can be read/write using following functions of Modbus RTU protocol:

- read of registers - function 3h
- write of registers - function 6h or 10h



- Maximum group size for 03h and 10h functions can not exceeds 16 registers (for single frame).
- The device interprets the broadcast messages, but then do not sends the answers.

If an error occurs while write or read of single register, then the device sends an error code according to Modbus RTU specifications:

| Error | Description |
|--------------|--|
| 01 | illegal function (only functions 03h, 06h and 10h are available) |
| 02 | illegal register address |
| 03 | illegal data value (out of permissible range) |

7.1. LIST OF REGISTERS

Registers described below (except 0x1004 register, which can be used for remote control while RS-485 mode) are available for read only. While attempt to write device sends error code 2 (illegal register address).

| Register | Write | Range | Register description |
|----------|-------|-------------|--|
| 0x0001 | No | - | high byte: door state: 0 – open, 1 – closed, 2 – opening, 3 – closing; low byte: current controller errors: 0 – no errors, 1 – barrier is active, 2 – door blockade, 3 – exceedance of kinetic energy, 4 – encoder failure, 5 – controller overheating; |
| 0x0002 | No | - | Current value of motor current [mA] |
| 0x0003 | No | - | Current speed [mm/s] |
| 0x0004 | No | - | Current position [mm/10] |
| 0x0005 | No | - | Mean speed [mm/s] |
| 0x0006 | No | - | Timer for creating chart time scale [ms/50] |
| 0x0007 | No | - | Control inputs state: bit 0 – { EXT. BARRIER. }, bit 1 – not used, bit 2 – { INSTALL. }, bit 3 – { CLOSE INP. }, bit 4 – { OPEN INP. }, bit 5 – { END SWITCH. }, |
| 0x0200 | No | - | Parameters structure version, hexadecimal |
| 0x0201 | No | 0 ÷ 1 | One use password state |
| 0x0202 | No | 0x18 ÷ 0x1B | Controller address (interface SLAVE) |
| 0x0203 | No | 4 | Baud rate |
| 0x0204 | No | 0 ÷ 1 | Permission of registers writing: 0 – writing prohibited ; 1 - writing permitted |
| 0x0205 | No | 0 ÷ 99 | Maximum delay between received messages: 0 – no control; 1 ÷ 99 - Maximum delay expressed in seconds |
| 0x0206 | No | 0 ÷ 5 | Additional delay of answer transmission |
| 0x0207 | No | 0000 ÷ 6000 | „ Open force ” parameter in „ Calibration ” menu, in [mA] |
| 0x0208 | No | 0000 ÷ 6000 | „ Close force ” parameter in „ Calibration ” menu, in [mA] |
| 0x0209 | No | 0 ÷ 99 | „ Threshold ” parameter in „ Calibration ” menu, in [%] |
| 0x020A | No | 0 ÷ 999 | Average current value of normal motor operation in [mA] |
| 0x020B | No | 0 ÷ 1000 | „ Open tigh. ” parameter in „ Calibration ” menu, w [mA] |
| 0x020C | No | 0 ÷ 1000 | „ Closed tigh. ” parameter in „ Calibration ” menu, w [mA] |
| 0x020D | No | 0 ÷ 1 | „ Tighten mode ” parameter in „ Calibration ” menu: 0 - continue; 1 - driven by CLOSING input |
| 0x020E | No | 0 ÷ 3 | „ Driver mode ” parameter in „ Working mode ” menu: 0 – RS-485 lines; 1 - external inputs; 2 - automatic; 3 - manual |
| 0x020F | No | 0 ÷ 3 | „ Door number ” parameter in „ Working mode ” menu: |

| Register | Write | Range | Register description |
|----------|-------|------------|--|
| 0x0210 | No | - | Door width in pulses, high byte |
| 0x0211 | No | - | Door width in pulses, low byte |
| 0x0212 | No | 200 ÷ 3999 | „ Width ” parameter in „ Doors data ” menu, in [mm] |
| 0x0213 | No | 10 ÷ 399 | „ Weight ” parameter in „ Doors data ” menu, in [kg] |
| 0x0214 | No | 0 ÷ 79 | „ V opening ” parameter in „ Speeds ” menu, in [cm/s] |
| 0x0215 | No | 0 ÷ 79 | „ V closing ” parameter in „ Speeds ” menu, in [cm/s] |
| 0x0216 | No | 50 ÷ 999 | „ Init. speed ” parameter in „ Calibration ” menu, in [0.1%] |
| 0x0217 | No | - | Acceleration/deceleration speed of door opening |
| 0x0218 | No | - | Acceleration/deceleration speed of door closing |
| 0x0219 | No | - | Start point of deceleration while opening in [mm] |
| 0x021A | No | - | Start point of deceleration while closing in [mm] |
| 0x021B | No | 0 ÷ 299 | „ Lock zone ” parameter in „ Calibration ” menu, in [mm] |
| 0x021C | No | 0 ÷ 1 | „ OPENING inp. ” parameter in „ Inputs ” menu: 0 – inactive; 1 - active; |
| 0x021D | No | 0 ÷ 1 | „ CLOSING inp. ” parameter in „ Inputs ” menu: 0 – inactive; 1 - active; |
| 0x021E | No | 0 ÷ 1 | „ OPEN switch ” parameter in „ Calibration ” menu: 0 – inactive; 1 - active; |
| 0x021F | No | 0 ÷ 2 | „ OPEN output ” parameter in „ Outputs ” menu: 0 – inactive; 1 - normal open; 2 - normal closed |
| 0x0220 | No | 0 ÷ 2 | „ CLOSED outp. ” parameter in „ Outputs ” menu: 0 – inactive; 1 - normal open; 2 - normal closed |
| 0x0221 | No | 0 ÷ 2 | „ BARRIER out. ” parameter in „ Outputs ” menu: 0 – inactive; 1 - normal open; 2 - normal closed |
| 0x0222 | No | 0 ÷ 2 | „ External ” parameter in „ Photocell ” menu: 0 – inactive; 1 – transfer; 2 - active |
| 0x0227 | No | 0 ÷ 1 | „ INSTALL inp. ” parameter in „ Inputs ” menu: 0 – inactive; 1 - active; |
| 0x0228 | No | - | Additional input (not used) |
| 0x0229 | No | 0 ÷ 1 | „ Language ” parameter in „ Region ” menu: 0 – Polish; 1 - English; |
| 0x022A | No | 0 ÷ 5 | „ Lock. speed ” parameter in „ Calibration ” menu: 0 – MIN.; 1 – 20% ... 5 – 100% |
| 0x022B | No | 0 ÷ 99 | „ Force reduc. ” parameter in „ Calibration ” menu, in [%] |
| 0x1004 | Yes | see desc. | Write only register , allows to door control while RS-485 mode: 0 – open, 0x100 – close, |

8. USER'S SETTINGS LIST

| Parameter | Description | Default value | User's value | Desc. page |
|---|---|-----------------|--------------|------------|
| Parameters of "1. Doors data" menu | | | | |
| 1.1 Width | Door width | 90,0 cm | | 18 |
| 1.2. Weight | Door weight | 250kg | | 18 |
| Parameters of "2. Speeds" menu | | | | |
| 2.1. V Opening | Door opening speed | 0,35 m/s | | 18 |
| 2.2. V Closing | Door closing speed | 0,35 m/s | | 18 |
| Parameters of "3. Calibration" menu | | | | |
| 3.2. Init. speed | Initialisation and calibration speed | 50,0 % | | 19 |
| 3.3. Close force | Closing force | 2,00A | | 20 |
| 3.4. Open force | Opening force | 2,80A | | 20 |
| 3.5. Open tigh. | tightening force of open door | 0,20A | | 20 |
| 3.6. Closed tigh. | tightening force of closed door | 0,10A | | 21 |
| 3.7. Tighten mode | Condition of using tightening force of closed door | continue | | 21 |
| 3.8. OPEN switch | End switch (terminal position contact) activation | inactive | | 21 |
| 3.9. Lock zone | Lock zone length | 4,0 cm | | 21 |
| 3.A. Lock. speed | Locking speed | MIN (2.5 cm/s) | | 21 |
| 3.C. Threshold | Permissible percentage exceedance of the average current value of opening+closing cycle | 35 % | | 22 |
| 3.E. Pause time | Delay of the automatic closing of the door | 0 s | | 22 |
| 3.F. Force reduc. | Force reduction at the ends of the door | 5 % | | 22 |
| Parameters of "4. Working mode" menu | | | | |
| 4.1. Driver mode | Device control mode | external inputs | | 23 |
| 4.2. Door number | Option used while remote control | 0 | | 23 |
| Parameters of "5. Inputs" menu | | | | |
| 5.1. OPENING inp. | {OPEN INP.} input activation | active | | 23 |
| 5.2. CLOSING inp. | {CLOSE INP.} input activation | active | | 23 |
| 5.3. INSTALL inp. | {INSTALL} input activation | active | | 24 |
| Parameters of "6. Outputs" menu | | | | |
| 6.1. OPEN output | {OPEN} output operation mode | normal open | | 24 |
| 6.2. CLOSED outp. | {CLOSED} output operation mode | normal open | | 24 |
| 6.3. BARRIER out. | {BARRIER} output operation mode | normal open | | 24 |
| Parameters of "7. Photocell" menu | | | | |
| 7.1. External | {EXT. BARRIER} input operation mode | inactive | | 24 |
| Parameters of "9. Region" menu | | | | |
| 9.1. Language | Language of menu content | polish | | 25 |

9. TECHNICAL DATA

| | |
|---|--|
| Power supply voltage | 22...24...38V DC; 22V...24...27V AC |
| Power consumption | max. 160 VA |
| Current value of motor control | max. 7A |
| Encoder input frequency | max. 40 kHz |
| PWM carrier frequency | 7200 Hz |
| Control inputs high logic level: low logic level: | high level active 7...24V...max.35V DC 0...2V DC |
| Relay outputs | NO contacts, 1A 30V DC / 1A 250V AC (cos ϕ = 1) |
| Power supply output for control inputs and external devices | 15V DC \pm 10% / max. 100 mA, stabilized |
| Communication interface (option) | RS 485, 8N1 and 8N2, Modbus RTU, not separated |
| Baud rate | 19200 bit/sec. |
| Display | LCD alphanumeric, 2 x 16 characters, backlit |
| Data memory | non-volatile memory, EEPROM type |
| Protection level | IP20 (if DB9 encoder connector put) |
| Housing | metal |
| Housing dimensions | 240 x 140 x 53 mm |
| Operating temperature | 0°C do +50°C |
| Storage temperature | -10°C do +70°C |
| Humidity | 5% do 90% no condensation |
| Altitude | up to 2000 meters above sea level |
| Screws tightening max. torque | 0,5 Nm |
| Max. connection leads diameter | 2,5 mm ² /power supply and motor connectors 1 mm ² /control input/output connectors |

TechWind Sp. z o.o.

Miszewko Dąbrowa 6

PL – 80-297 Banino k/Gdańska, Poland

tel. : (+48 58) 684 86 19-20 , fax: (+48 58) 684 86 17

<http://www.techwind.pl>, e-mail: biuro@techwind.pl