

Dojście do maszynowni A lub B

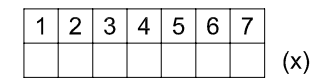

Q kg	v m/s	typ	standardowe wym.			nadszybie		odl. pomiędzy poziomami	podszybie GP=		
			SK=	GK=	WK=	WK <800	WK >800				
100	0,30	100.30/2	400	600 1000	800	800	1000	1200	WK+1190	2xWK +330	WK/2 +130
300	0,30	300.30/15	1000	800 1000	1200			WK+1300	1,5xWK +790		

Dźwig towarowy z drzwiami gilotynowymi na poz. posadzki z kabiną przelotową lub nieprzelotową

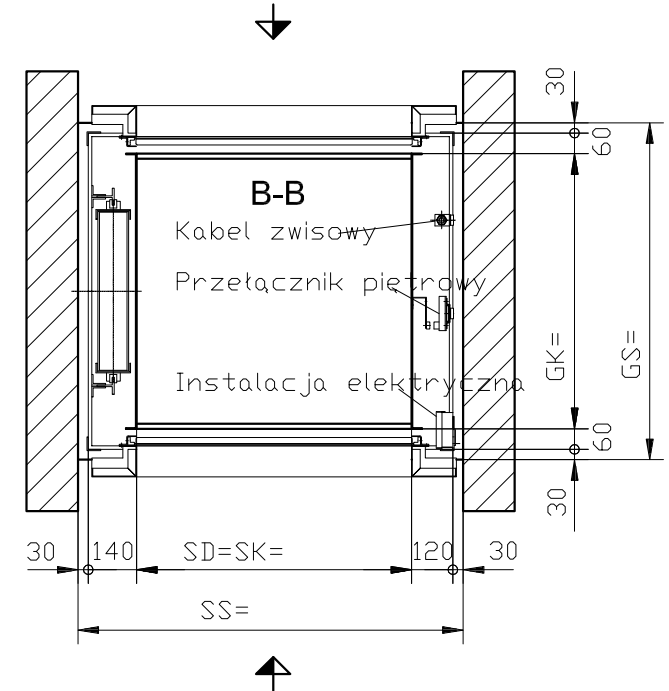
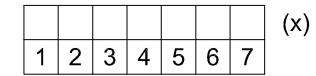
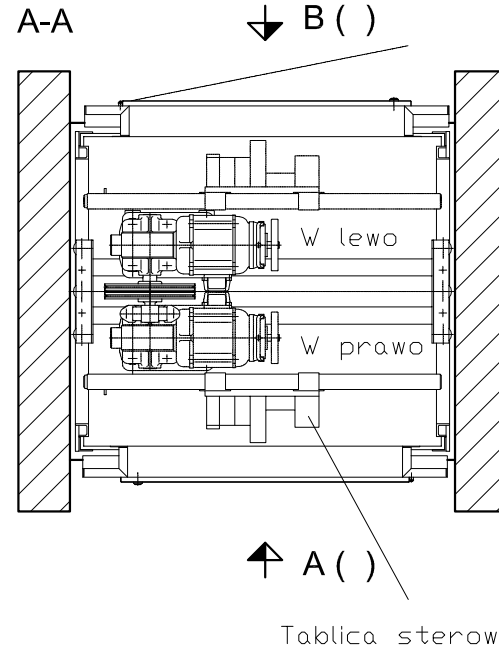